

FEATURES

- TFT-Active Matrix-LCD Drive System
- 240 (V) × 720 (H) (Total 172,800) Dots (Delta Configuration)
- Slim, Lightweight and Compact:
 - Active Area/Outline Area: 57%
 - Thickness: 23 mm
 - Weight: 320 g
- Built-in Video Interface Circuit (including chroma demodulator, picture tone, video ACG circuit) and Control Circuit Responsive to Composite Video Signal
- Also Responsive to Standard Analog RGB Video Signals
- Further RGB Signals can be Superimposed on Composite Video Signal (in this case, RGB signals shall be digital input signal for eight colors display)
- High-Quality, Full-Color Rendition With Backlight Source Incorporated
- Viewing Angle:
 - 6 O’Clock Direction: LQ6NC01
 - 12 O’Clock Direction: LQ6NC02

DESCRIPTION

The SHARP LQ6NC01/LQ6NC02 Color TFT-LCD module is an active matrix LCD (Liquid Crystal Display) produced by making the most of Sharp’s expertise in liquid-crystal and semiconductor technologies. The active device is amorphous silicon TFT (Thin Film Transistor). The module accepts full-color video signals (composite video and analog RGB) conforming to the NTSC (M) system standard.

When additionally provided with the backlight-driving DC/AC inverter, it is applicable to pocket TVs and various display monitors.

The module consists of a TFT-LCD panel, driver ICs, control PWB mounted with electronic circuits, fluorescent tube, reflector, frame, front and rear shielding cases.

NOTE: Backlight-driving DC/AC inverter is not built into the module.

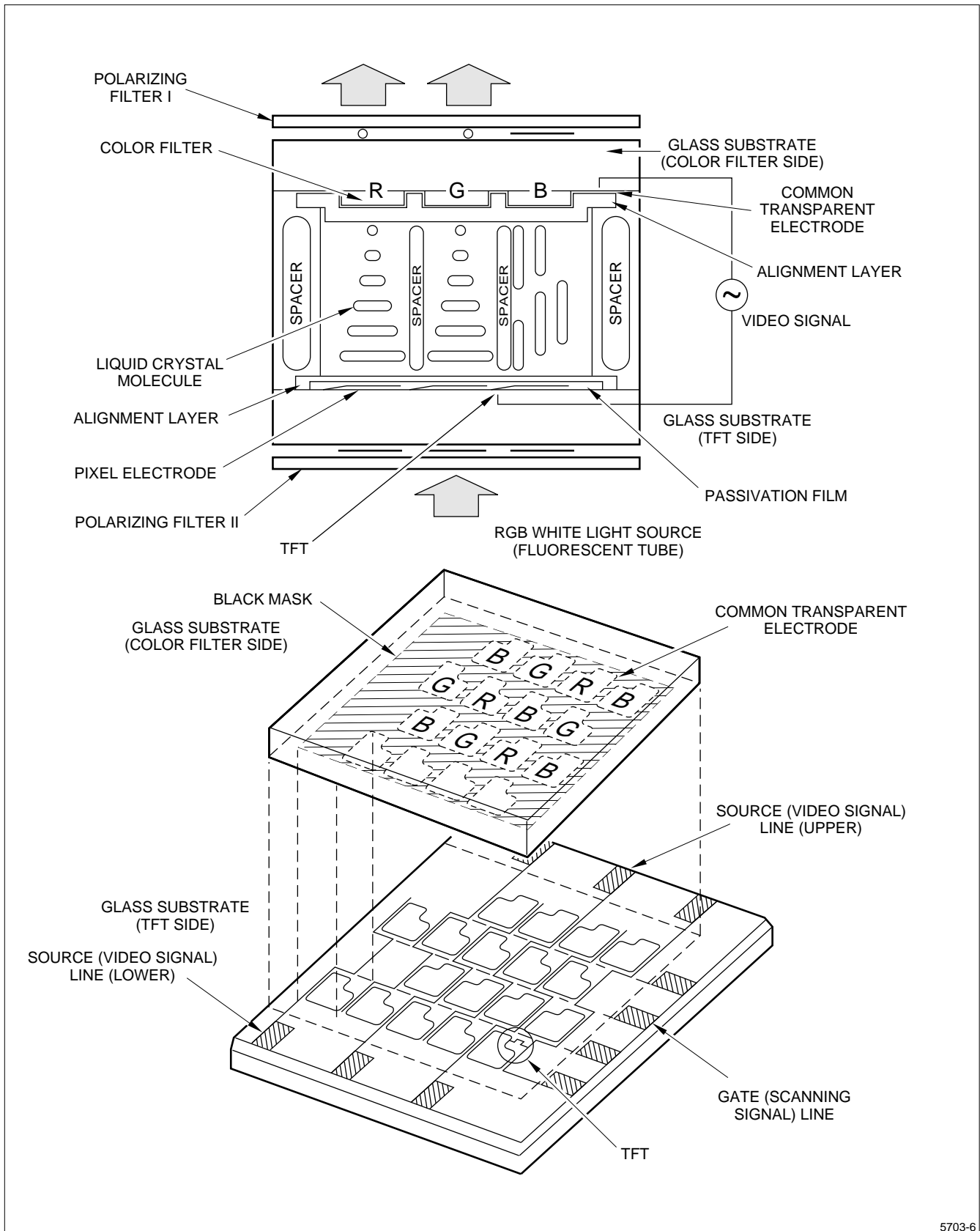

5703-6

Figure 1. LQ6NC01/LQ6NC02 TFT-LCD Panel

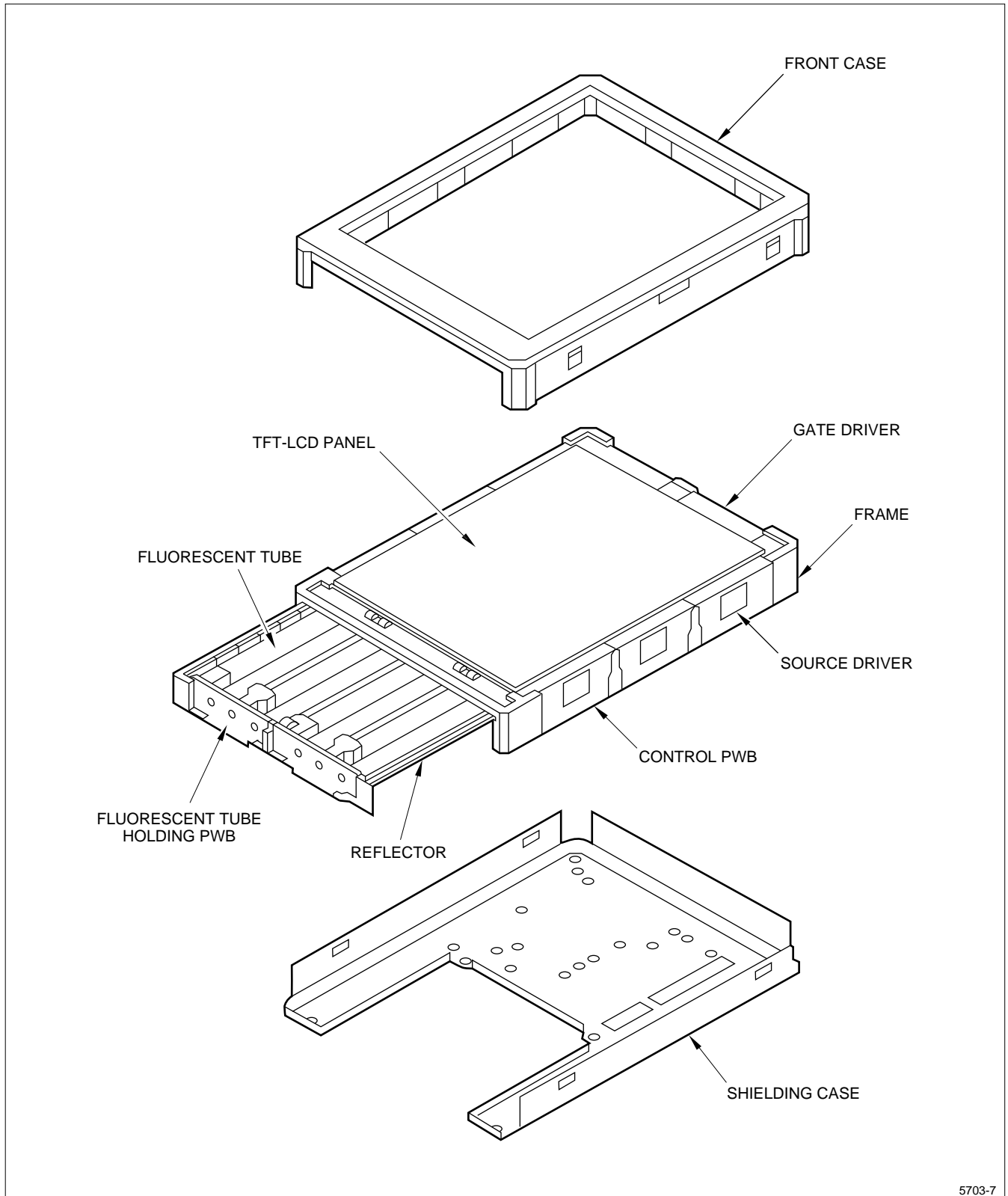

5703-7

Figure 2. LQ6NC01/LQ6NC02 TFT-LCD Module Construction

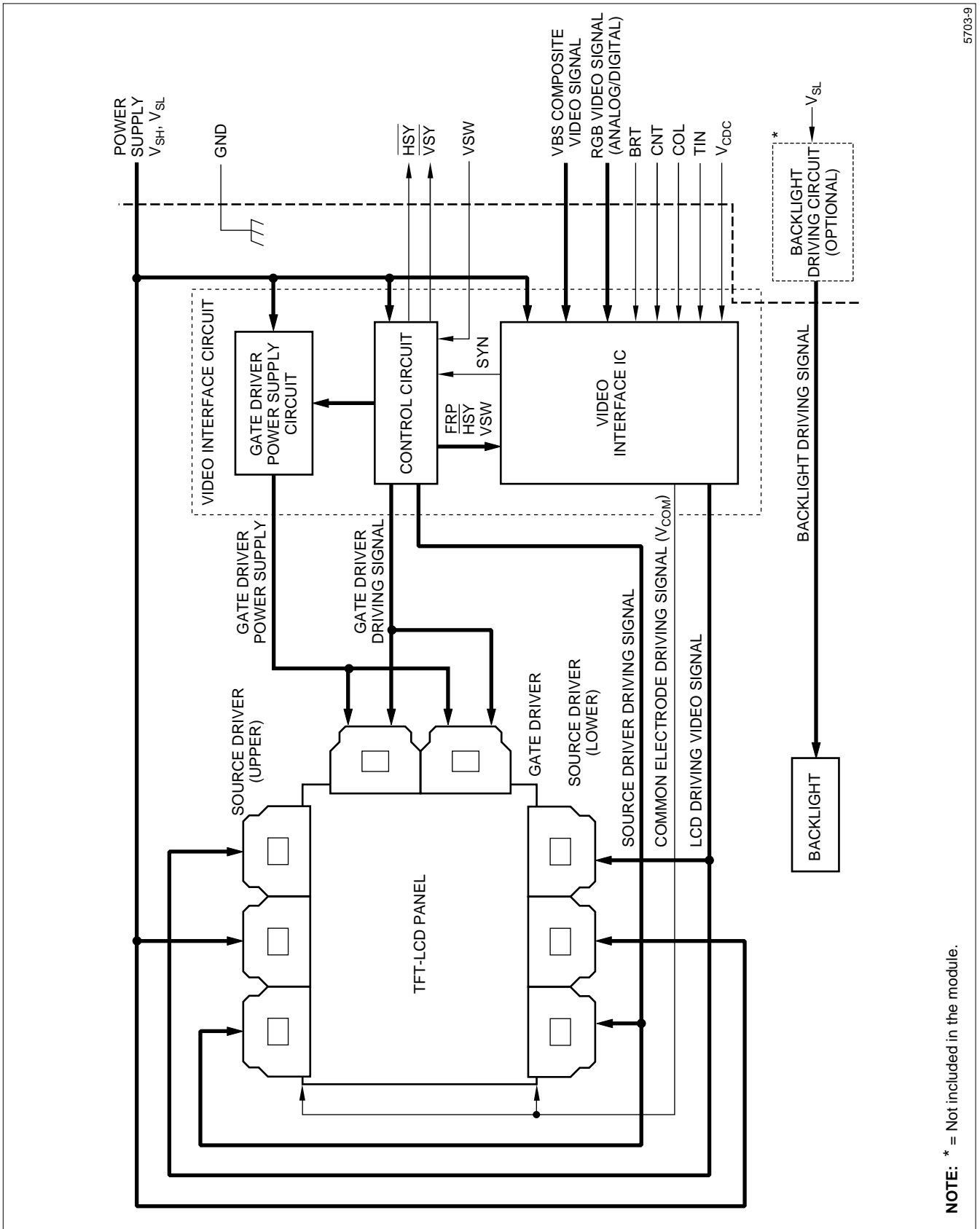

Figure 3. LQ6NC01/LQ6NC02 TFT-LCD Module Block Diagram

MECHANICAL SPECIFICATIONS

PARAMETER	SPECIFICATIONS	UNIT	NOTE
Display Format	720 (W) × 240 (H)	dots	–
Active Area	113.8 (W) × 87.6 (H)	mm	–
Screen Size	5.7 (Diagonal)	inch	–
Dot Pitch	0.158 (W) × 0.365 (H)	mm	–
Dot Configuration	RGB Delta Configuration	–	–
Outline Dimension	149.4 (W) × 117 (H) × 23 (D)	mm	1
Weight	320 ±10	g	–

NOTE:

1. Excludes protrusions.

ABSOLUTE MAXIMUM RATINGS (GND = 0 V, t_A = 25°C)

SYMBOL	PARAMETER	MIN.	MAX.	UNIT	NOTE
V _{SH}	Positive Power Supply Voltage	–0.3	+6.0	V	–
V _{SL}	Negative Power Supply Voltage	–9.0	+0.3	V	–
V _{i1}	Video Input Signal 1	–	2.0	V _{P-P}	1
V _{i2}	Video Input Signal 2	–	V _{SH} –0.3	V _{P-P}	2
V _I	Digital Input/Output Signals	–0.3	V _{SH} +0.3	V	3
V _{CDC}	DC Bias Voltage of Common Electrode Driving Signal	V _{SL} –0.3	–1.5	V	–
V _{PIC}	Picture Adjusting Terminal Voltage	–0.3	V _{SH} –0.3	V	4
T _{STG}	Storage Temperature	–25	60	degrees	5
T _{OPP}	Operating Temperature – Panel	0	60	degrees	
T _{OPA}	Operating Temperature – Ambient	0	40	degrees	

NOTES:

1. VBS terminal (composite video signal).
2. VRI, VGI, VBI, terminals (RGB signals).
3. $\overline{\text{HSY}}$, $\overline{\text{VS\`Y}}$, VSW terminals.
4. BRT, CNT, COL, TIN terminals.
5. Maximum wet-bulb temperature 38°C or less. No dew condensation.

INPUT/OUTPUT TERMINALS – TFT-LCD PANEL DRIVING SECTION

PIN NUMBER	SYMBOL	I/O	DESCRIPTION	NOTE
1	$\overline{\text{HSY}}$	O	Internal Horizontal Sync Signal (In phase with VBS)	–
2	$\overline{\text{VS Y}}$	O	Internal Vertical Sync Signal (In phase with VBS)	–
3	TST	–	This is Electrically Opened During Operation	–
4	NC	–		
5	TST	–		
6	GND	I	Ground	–
7	VSW	I	Selection Signal of Two Sets of Video Signals	1
8	GND	I	Ground	–
9	V_{CDC}	I	DC Bias Voltage Adjusting Terminal of Common Electrode Driving Signal	2
10	VSH	I	Positive Power Supply Voltage	–
11	VBS	I	Composite Video Signal	3
12	BRT	I	Brightness Adjusting Terminal	4
13	CNT	I	Contrast Adjusting Terminal	
14	COL	I	Color Gain Adjusting Terminal	
15	TIN	I	Tint Adjusting Terminal	
16	VSL	I	Negative Power Supply Voltage	–
17	VRI	I	Color Video Signal – Red	5
18	VGI	I	Color Video Signal – Green	
19	VBI	I	Color Video Signal – Blue	
20	GND	I	Ground	–

NOTES:

In the following descriptions, 'High' means 'VSH' and 'Low' means 'GND.'

- Selects input signals, composite or RGB:
 - When VSW is 'High' or open, composite video signal (Pin Number 13) is selected.
 - When VSW is 'Low,' RGB signal set (Pin Numbers 17 through 19) is selected.
- Common electrode driving signal (V_{COM}) generated in the module is observed on the pin. This should be opened during operation, since the DC component of V_{COM} (V_{CDC}) is adjusted before shipping to the optimum value with V_{SH} and V_{SL} being the typical value. If the optimum value changes (for example, lowering of the power source), it should be re-adjusted with the built-in variable resistor (V_{CDC}) or external circuit shown in Figure 5. Refer to 'Adjusting Method of Optimum Common Electrode DC Bias Voltage' for readjusting.
- Similarly, in case of RGB input, apply composite video signal or composite sync signal (with negative polarity) for sync separator.
- Brightness, Contrast, Color Gain and Tint are adjusted by the DC voltage supplied to each pin. (Contrast, color gain, and tint are not available for RGB signal input). They are adjusted to the optimum value on shipping but they can be re-adjusted with the built-in variable resistor (BRT, CNT, COL, TIN) or external circuit shown in Figure 5. (However, since the contrast is adjusted to maximize display characteristics, it is recommended not to readjust it and to keep outer adjustment terminals open.)
- Responsive to 0 $V_{\text{P-P}}$ to 0.7 $V_{\text{P-P}}$ analog RGB signal when VSW is fixed to 'Low.'
 - In case of superimposing on composite video signal as on screen display (refer to Note 1), RGB signals shall be digital signal (Low: 0 $V_{\text{P-P}}$ High: > 2 $V_{\text{P-P}}$ available for eight colors display).

INPUT/OUTPUT TERMINALS – BACKLIGHT DRIVING SECTION

PIN NUMBER	SYMBOL	I/O	DESCRIPTION	NOTE
L1	VL1	I	Power Supply For Fluorescent Tube (1) (GND)	1
L2	NC	–	No Connection	–
L3	VL2	I	Power Supply For Fluorescent Tube 1 (High)	–
L4	VL3	I	Power Supply For Fluorescent Tube 2 (High)	–
L5	NC	–	No Connection	–
L6	VL4	I	Power Supply For Fluorescent Tube (2) (GND)	1

NOTE:

- Should be grounded by the backlight driving DC/AC inverter, as the L1 and L6 terminals are connected with the shielding film in the module. These terminals will be grounded by the optional DC/AC inverter. For internal electrical connection of backlight unit, see Figure 4.

CAUTION: Shielding case is separated from GND terminal and electrically open.

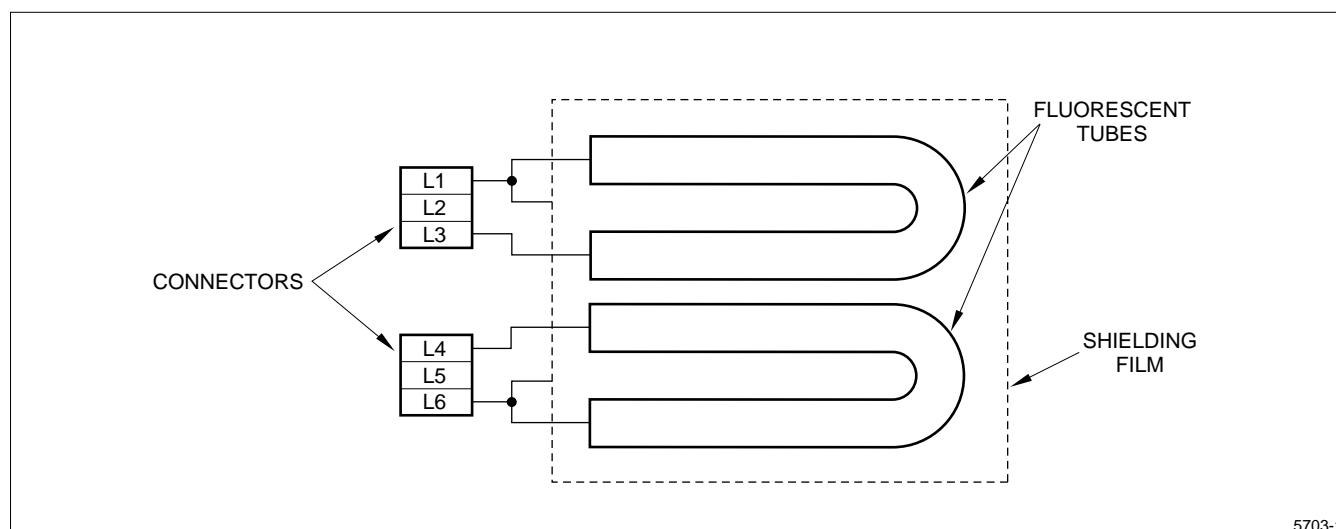

5703-1

Figure 4. Wiring Diagram of Backlight Unit

RECOMMENDED OPERATING CONDITIONS – TFT-LCD Panel Section (GND = 0 V, $t_A = 25^\circ\text{C}$)

SYMBOL	PARAMETER	MIN.	TYP.	MAX.	UNIT	NOTE
V_{SH}	Positive Power Supply Voltage	+4.8	+5.0	+5.2	V	–
V_{SL}	Negative Power Supply Voltage	–7.6	–8.0	–8.4	V	–
VBS	Video Input Signal Amplitude (Peak Level)	0.7	1.0	1.3	V_{P-P}	1
$V_{RGB (1)}$		–	0.7	–	V_{P-P}	2
$V_{RGB (2)}$		2.0	–	4.0	V_{P-P}	3
V_{iOC}	Video Input Signal DC Component	–1.0	0	+1.0	V	4
V_{iN}	Digital Input Voltage – High Level	+3.5	–	V_{SH}	V	5
V_{iL}	Digital Input Voltage – Low Level	0	–	+1.5	V	–
V_{oH}	Digital Output Voltage – High Level	+3.5	–	V_{SH}	V	6
V_{oL}	Digital Output Voltage – Low Level	0	–	+1.5	V	–
V_{cDC}	DC Bias Voltage of Common Electrode Driving Signal	–4.5	–3.5	–2.5	V	7

NOTES:

- VBS (composite video signal):
Input impedance: 75 Ω .
Amplitude of sync signal: $>0.2 V_{P-P}$.
- VRI, VGI, VBI terminals (RGB signals for analog display).
Input impedance: $>10 \text{ k}\Omega$.
- VRI, VGI, VBI terminals (RGB signals for superimposing).
Input impedance: $>10 \text{ k}\Omega$.
- VBS, VRI, VGI, VBI terminals.
- VSW terminal.
Input impedance: $>50 \text{ k}\Omega$.
- \overline{HSY} , \overline{VSX} terminals (internal sync signals).
Load resistance: $>20 \text{ k}\Omega$.
- Adjusted for each module so as to attain maximum contrast ratio.
Refer to 'Adjusting Method of Optimum Common Electrode DC Bias Voltage' for adjusting.

RECOMMENDED OPERATING CONDITIONS – BACKLIGHT DRIVING SECTION ($t_A = 25^\circ\text{C}$)

SYMBOL	PARAMETER	CONDITION	MIN.	TYP.	MAX.	UNIT
V_L	Lamp Voltage	Just for reference	290	330	370	V RMS
I_L	Lamp Current		6.0	7.0	8.0	mA RMS
f_L	Frequency	–	20	–	50	kHz
V_S	Kick-Off Voltage	–	800	–	–	V RMS

NOTE:

DC/AC inverter for driving cold cathode fluorescent tube (CCFT) is not built in the module.
DC/AC inverter for external connection (Model Number LQ0J04) is optionally available.

POWER CONSUMPTION ($t_A = 25^\circ\text{C}$)

SYMBOL	PARAMETER	CONDITION	MIN.	TYP.	MAX.	UNIT	NOTE
I_{SH}	Power Consumption by the Panel Section – Positive Supply Current	$V_{SH} = +5.0\text{ V}$ $V_{SL} = -8.0\text{ V}$	–	+120	+155	mA	–
I_{SL}	Power Consumption by the Panel Section – Negative Supply Current		–	–90	–120	mA	–
W_S	Power Consumption by the Panel Section – Total		–	1.32	1.73	W	1
W_L	Power Consumption by the Fluorescent Tube Section	On rated lighting	–	4.6	6.0	W	2

NOTES:

1. Excludes power consumption by the backlight.
2. Calculated reference value ($I_L \times V_L$).

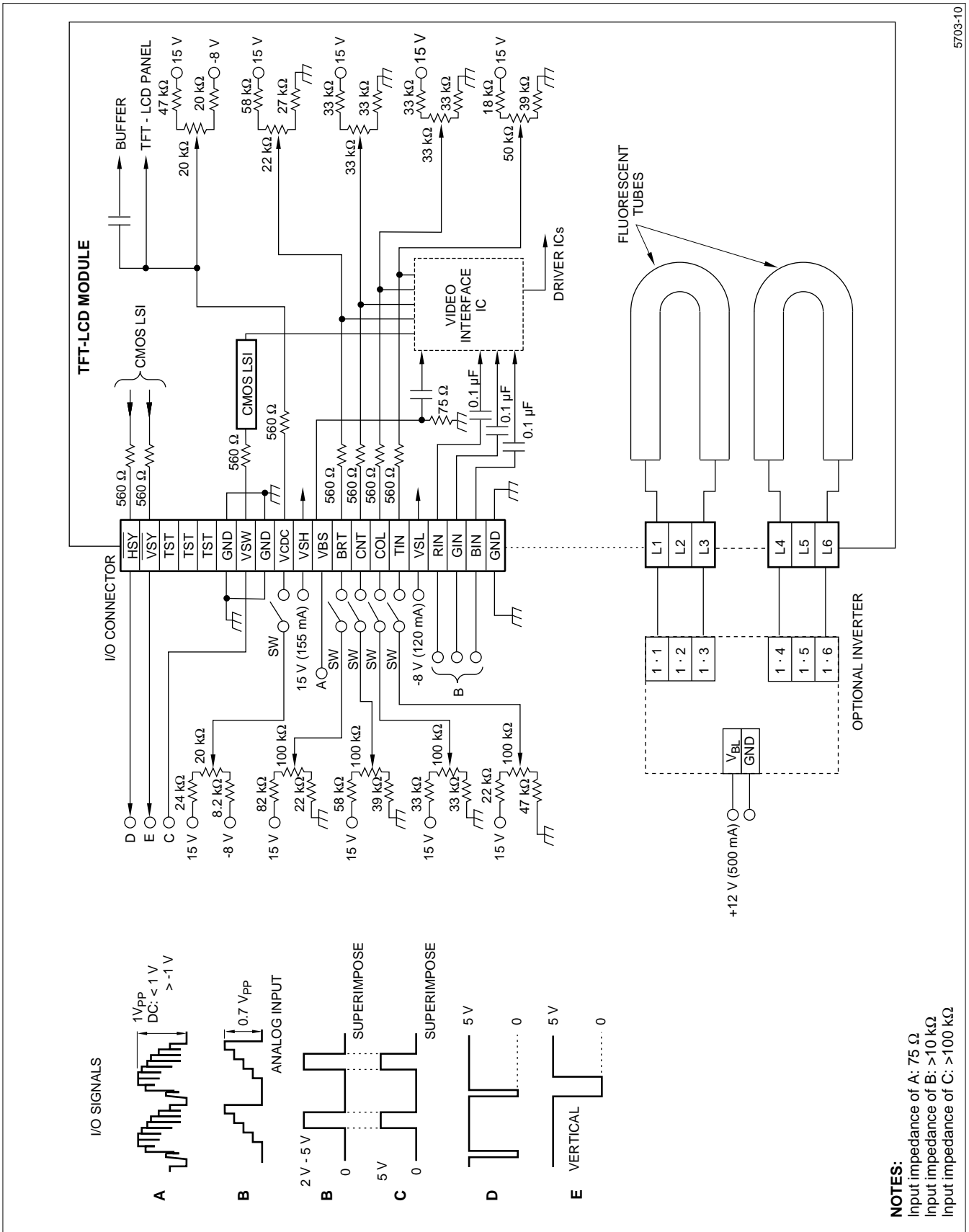

5703-10

Figure 5. TFT-LCD Module Recommended Circuit

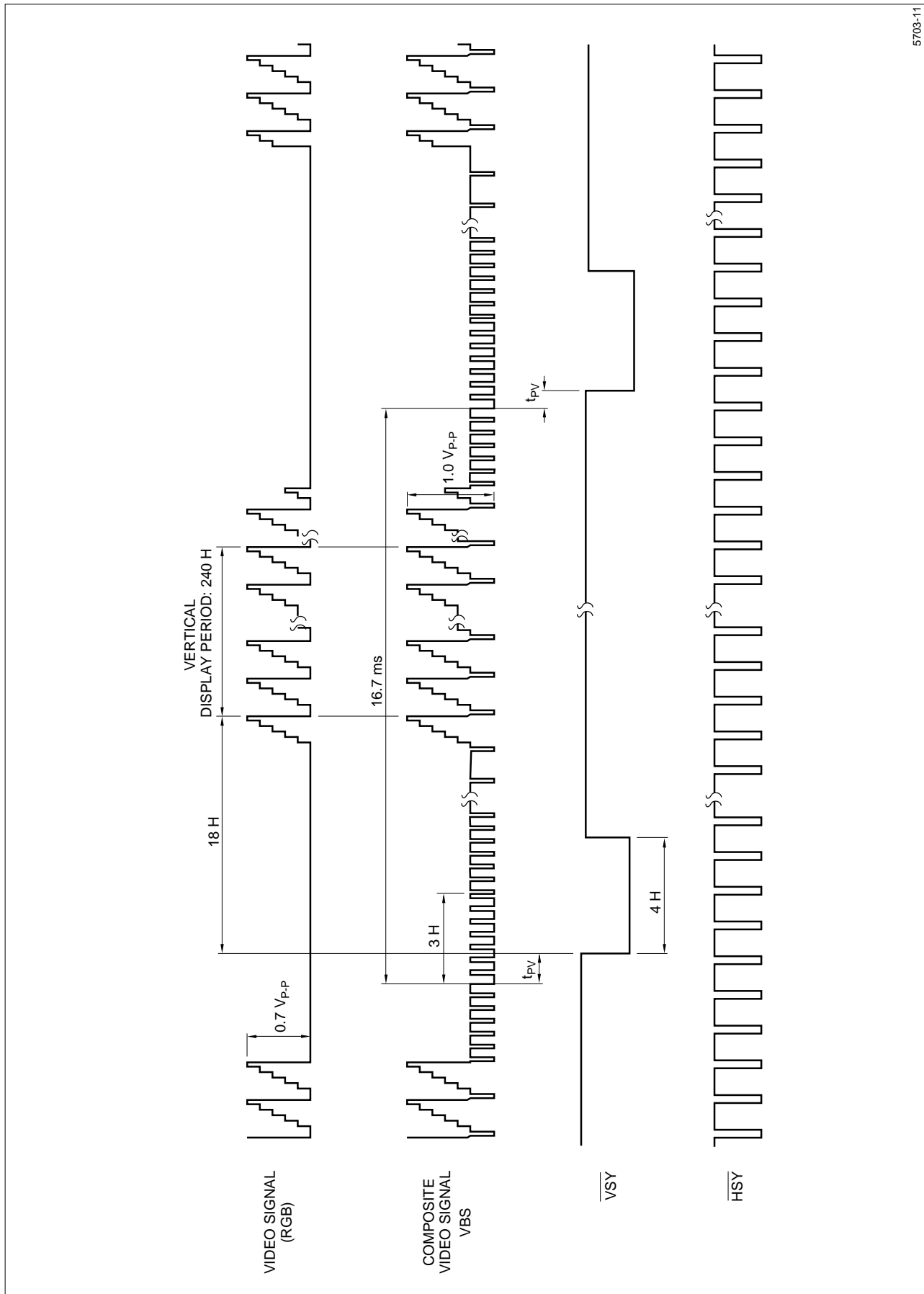

5703-11

Figure 6. Input/Output Signal Waveforms

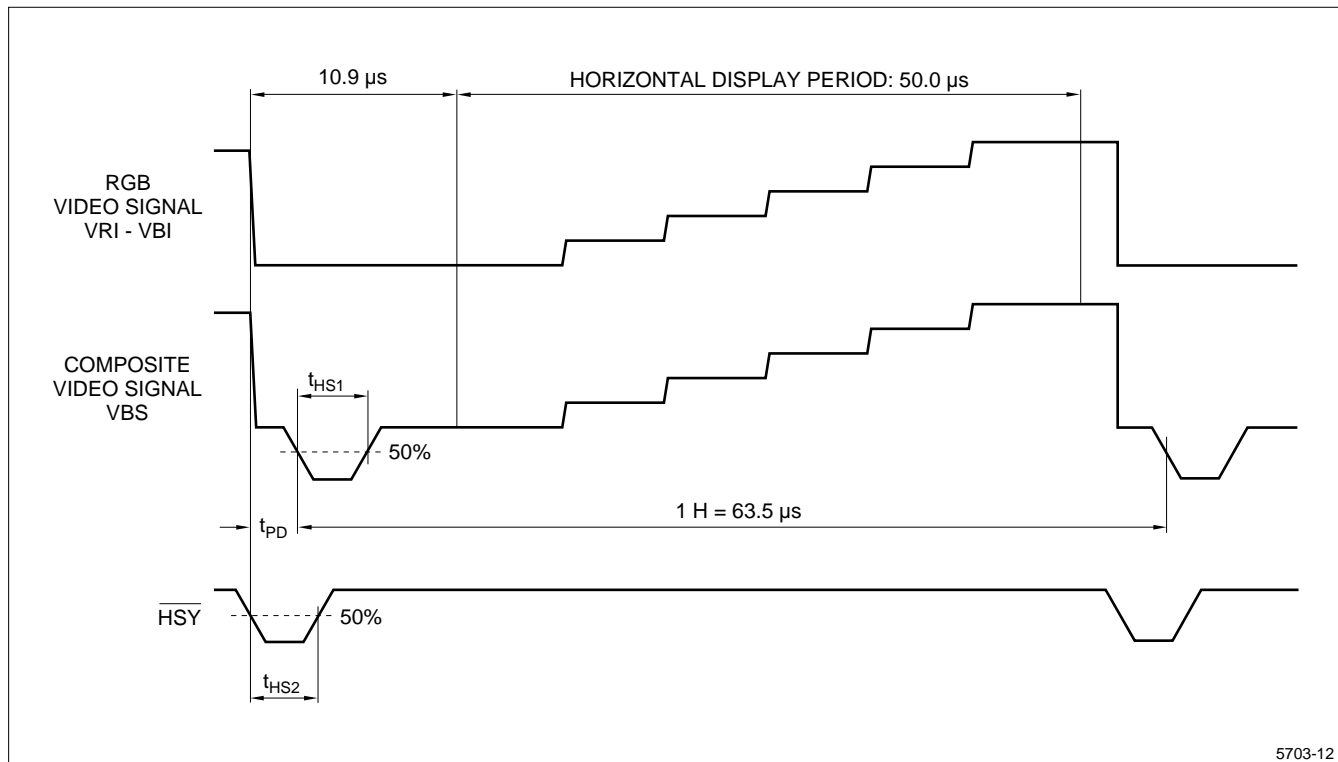

5703-12

Figure 7. Input/Output Signal Timing Chart

TIMING CHARACTERISTICS – INPUT/OUTPUT SIGNALS ($V_{SH} = +5\text{ V}$, $V_{SL} = -8\text{ V}$) ($f_H = 15.7\text{ kHz}$, $f_V = 60\text{ Hz}$)

SYMBOL	PARAMETER	CONDITION	MIN.	TYP.	MAX.	UNIT	NOTE
t_{HS1}	Horizontal Sync – Input Pulse Width	–	4.2	4.7	5.7	ms	–
t_{HS2}	Horizontal Sync – Output Pulse Width	$f = f_H$	2.3	3.0	4.6		1
t_{pd}	Horizontal Sync Phase Difference	–	–1.5	–	1.3		2
t_{vs}	Vertical Sync Output Pulse Width	$4/f_H$	243	256	269		–
t_{pv}	Vertical Sync Phase Difference	–	67/33	73/39	79/45		3

NOTES:

- Adjusted by variable resistor (H-POS).
- Variable range by variable resistor (H-POS). (Positive when \overline{HSY} proceeds VBS.) Adjusted value: $t_{pd} = 0.1\ \mu\text{s} \pm 0.7\ \mu\text{s}$.
- Odd field/Even field ($1/f_H/0.5/f_H$).

Display Time Range

- Horizontally: $10.9\ \mu\text{s}$ to $61.0\ \mu\text{s}$ from the falling edge of \overline{HSY} .
- Vertically: 19H to 258H from the falling edge of \overline{VS} .

OPTICAL CHARACTERISTICS

SYMBOL	PARAMETER	CONDITION	MIN.	TYP.	MAX.	UNIT	NOTE
$\Delta\theta 11$	Viewing Angle Range	CR ≥ 10	30 (10)	–	–	degrees	LQ6NC01 (LQ6NC02) 1, 2
$\Delta\theta 12$			10 (30)	–	–		
$\Delta\theta 2$			45	–	–		
CR _{MAX}	Contrast Ratio	$\theta = 0^\circ$	30	–	–	–	2, 3
t _R	Response Time – Rise	$\theta = 15^\circ$	–	30	–	ms	2
t _D	Response Time – Decay		–	50	–	ms	4
Y _L	Brightness	–	100	120	–	nt	5
K _L	Color Temperature	$\theta = 0^\circ$	–	7900	–	K	5
x	White Chromaticity		0.247	0.297	0.347	–	
y			0.262	0.312	0.362	–	

NOTES:

- Viewing angle range is defined in Figure 8.
- Applied voltage for measuring optical characteristics:
 - V_{DC} must be adjusted by the Flicker measuring method or the Contrast measuring method described in 'Adjusting Method of Optimum Common Electrode DC Bias Voltage.'
 - Brightness adjusting terminal (BRT) should be opened.
 - Video signal of reference black level and 100% white level must be input.
- Contrast ratio is calculated with the following formula in the optical characteristics measuring method shown in Figure 10:

$$\text{Contrast ratio (CR)} = \frac{\text{Photodetector output with LCD being 'white'}}{\text{Photodetector output with LCD being 'black'}}$$
- Input signals are applied to the area measured to make the area 'white' and 'black' respectively, and change with time in the photodetector output is measured in the optical characteristics measuring method shown in Figure 10.
- Measured on the center area of the panel at the viewing cone 1° by TOPCON luminance meter BM-7.

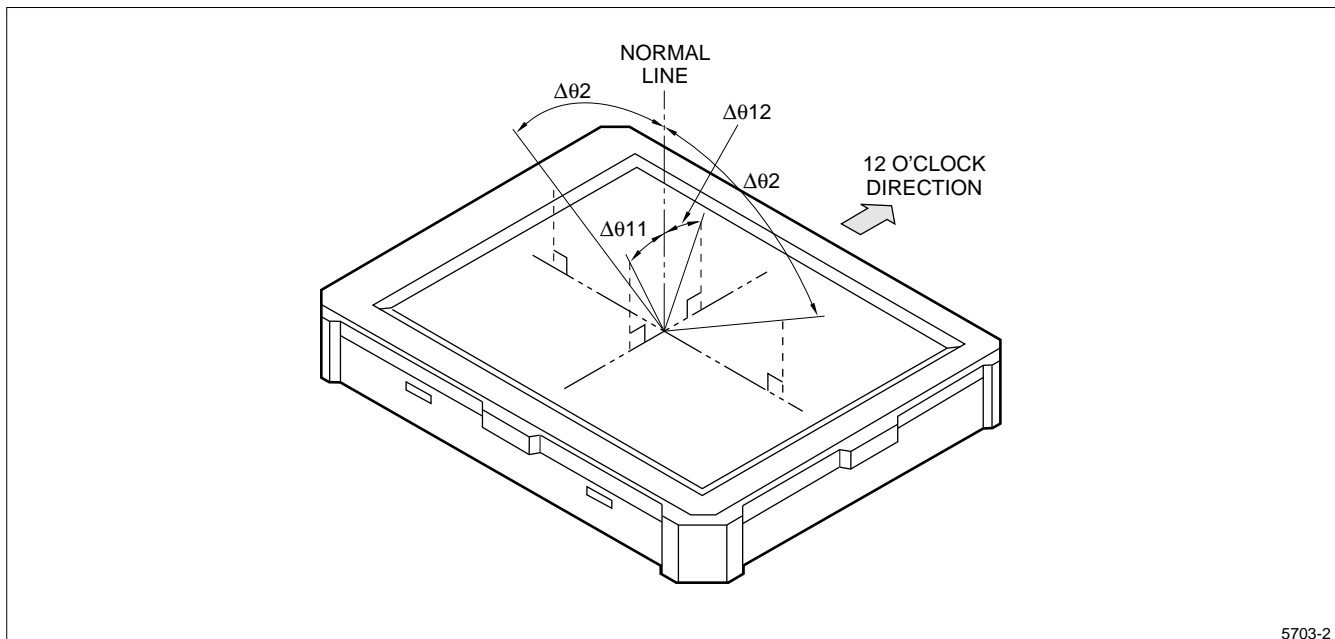

Figure 8. Definition of Viewing Angle Range

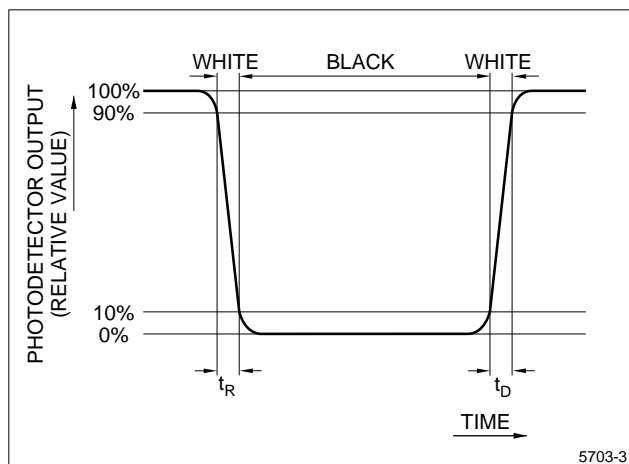

Figure 9. Definition of Response Time

MECHANICAL CHARACTERISTICS

External Appearance

There shall not be any conspicuous defects. (See Outline Dimensions diagram.)

Panel Durability

The panel shall not break when the panel center is pressed with 2 kg force by 15 mm diameter smooth flat surface.

CAUTION: The least force can cause functional troubles if it is applied on the active area for a long time.

I/O Connector Performance

I/O connector of LCD panel driving circuit (FPC connector 20 pins):

- Applicable FPC: Shown in Figure 11.
- Terminal holding force: 100 g or larger/pin. (Each terminal is pulled out at a rate of 25 ± 3 mm/minute)
- Insertion/pulling durability: Contact resistance not larger than double the initial value after applicable FPC is inserted and pulled out 20 times.

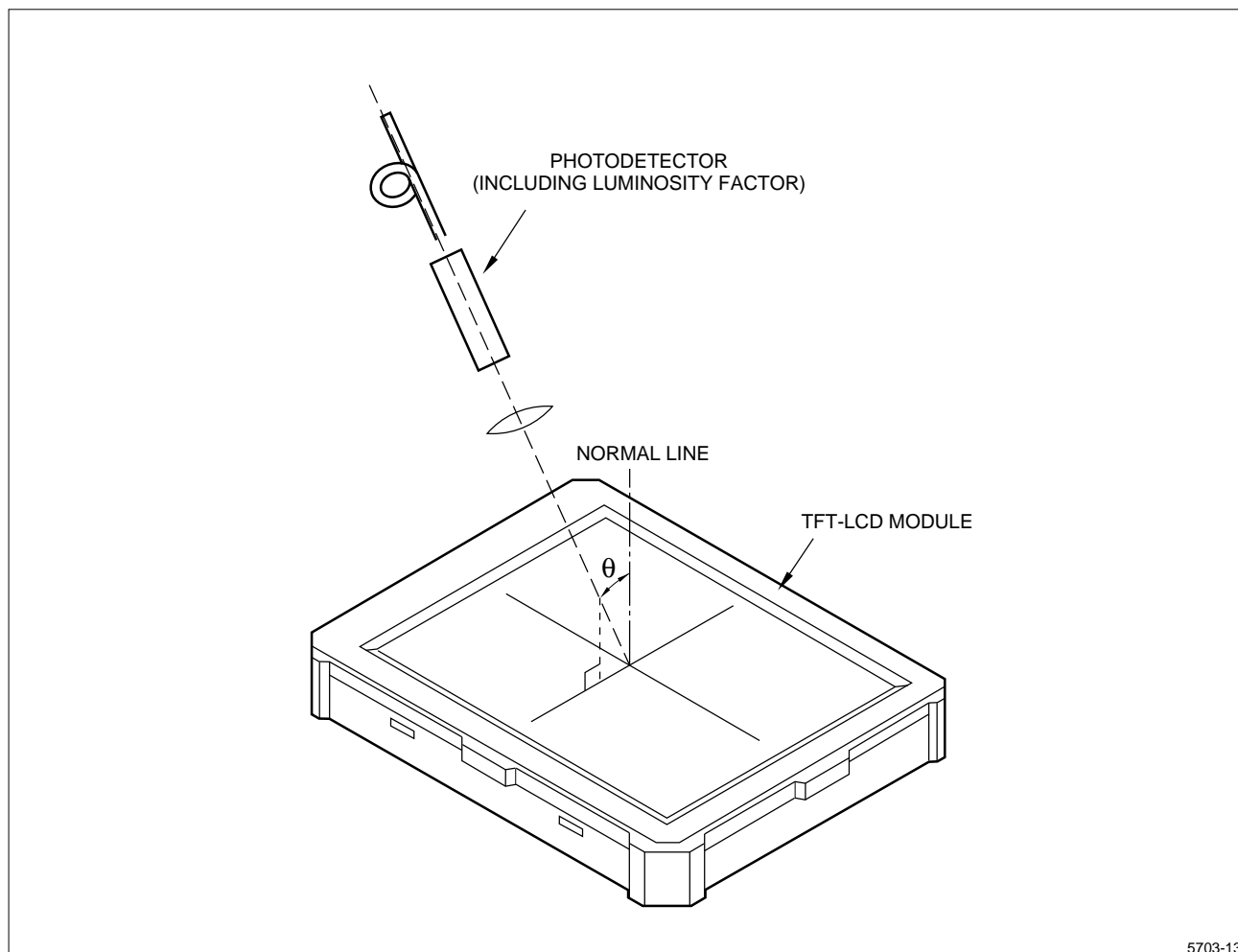

Figure 10. Optical Characteristics Measuring Method

I/O Connector of Backlight Driving Circuit (XH connector 3 pins x 2 pcs.)

- Applicable connector housing: XHP-3 (produced by Japan Solderless Terminal)
- Terminal holding force: 100 g or more/pin. (Pulled out at a rate of 1 through 5 mm/second)
- Insertion/pulling durability: Contact resistance not larger than double the initial value after connectors are inserted and pulled out 20 times.

DISPLAY QUALITY

The display quality of the color TFT-LCD module shall be in compliance with the Delivery Inspection Standard (Separate Sheet LDI-90522).

HANDLING INSTRUCTIONS

Mounting of Module

The TFT-LCD module is designed to be mounted on equipment using the mounting tabs in the four corners of the module rear face. When mounting the module, use the M3 tapping screw (fastening torque is 5 through 6 kg•cm). Be sure to fix the module on the same plane, taking care not to warp or twist the module. Be sure that the power source is off when inserting/pulling out I/O connector of the module.

Precautions in Mounting

- The polarizer, which is made of soft material and susceptible to flaws, must be handled carefully. A protective film (laminator) is applied to the surface to protect it against scratches and dirt. Peel off the laminator just before using to avoid static electricity.
- Use caution when peeling off the laminator.

Working Environment

When the laminator is peeled off, static electricity may cause dust to stick to the polarizer surface. To avoid this, the following working environment is desirable:

- Floor: Conductive (anti-electrostatic) treatment of 1 MΩ or more on the tile or a conductive mat or conductive paint on the tile
- Clean, dust-free room with an adhesive mat placed in the doorway
- Humidity: 50% to 70% RH
- Workers shall wear conductive (anti-electrostatic) shoes, conductive work clothes, conductive gloves and a ground strap.

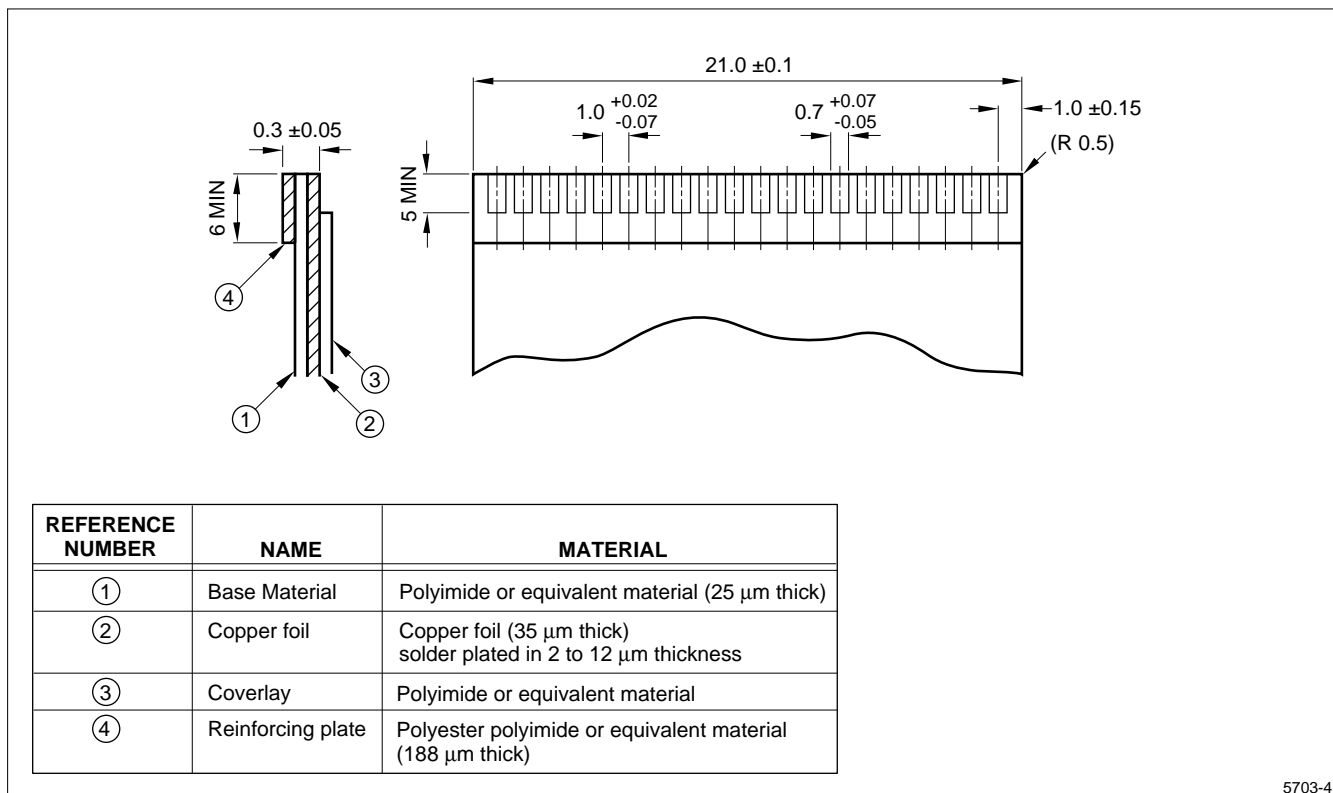

5703-4

Figure 11. Applicable FPC For I/O Connector (1.0 mm pitch)

Working Procedures

- Direct the wind of the heated ionized air discharging blower somewhat downward to ensure that the module is blown sufficiently. Keep the distance between module and the blower within 20 cm (see Figure 12A).
- Attach adhesive tape to the laminator part near the discharging blower to protect polarizer against flaws (see Figure 12B).
- Peel off laminator, pulling adhesive tape slowly to your side taking five or more seconds. It is important it take more than five seconds.
- After peeling off the laminator, pass the module to the next work process immediately without getting the module dusty.
- Method of removing dust from polarizer:
 - Blow off dust with N₂ blower for which static electricity preventive measures have been taken. An ionized air gun (Hugle Electronics Co.) is recommended.
 - Since the polarizer is vulnerable, wiping should be avoided. If wiping is unavoidable, wipe it carefully with lens cleaning cloth, breathing on it. 'Belleseime' (Kanebo, Ltd.) is desirable.
- When metal parts of the TFT-LCD module (shielding lid and rear case) are soiled, wipe them with a soft, dry cloth. For stubborn dirt, wipe the part, breathing gently on it.

- Wipe off liquid immediately since it can cause color changes and staining.
- The LCD is made of glass plates. Use care when handling it to avoid breakage.
- This unit contains CMOS LSIs which are sensitive to electrostatic charges. Take care to protect the unit from electrostatic discharge.

Precautions In Adjusting Module

- Adjusting volumes on the rear face of the module have been set optimally before shipment. Therefore, do not change any adjusted values. If adjusted values are changed, the specifications described in this technical literature may not be satisfied.

Other Precautions

- Do not expose the module to direct sunlight, strong ultraviolet light, etc., for prolonged periods.
- Store the unit at normal room temperature to prevent the LC from converting to liquid (due to excessive temperature changes).
- If the LCD panel breaks, the liquid crystal may escape from the panel. The liquid crystal is harmful, so do not put it into the eyes or mouth. When liquid crystal sticks to hands, feet or clothes, wash it out immediately with soap.
- Observe all other precautionary requirements in handling general electronic components.

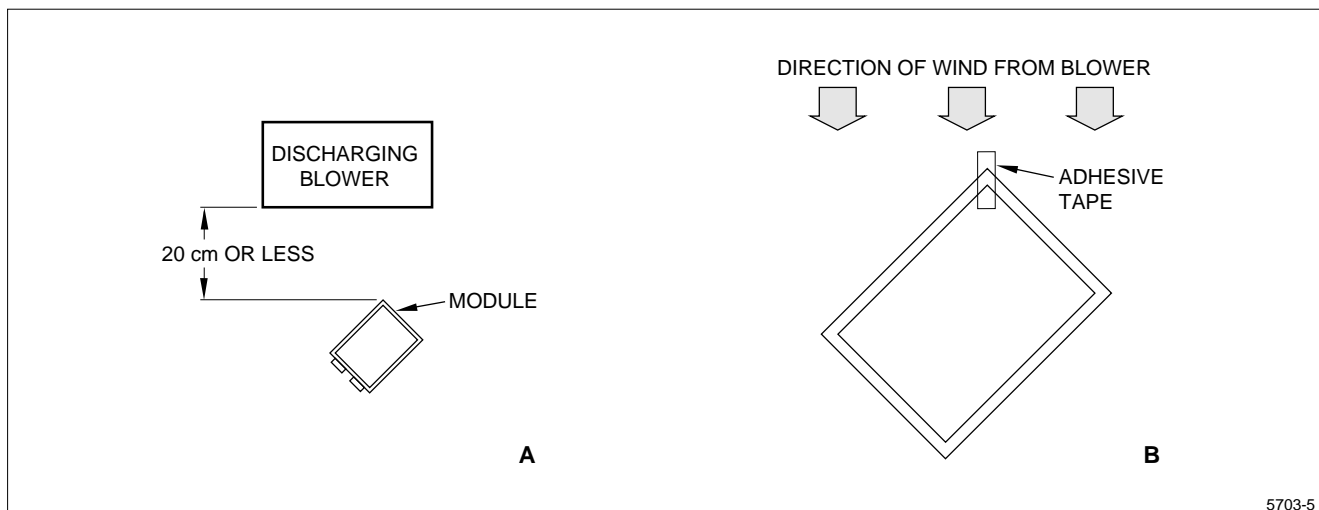

Figure 12. Proper Use of Discharging Blower

SHIPPING REQUIREMENTS

Packing form is shown in Figure 13.

Carton Storage Conditions

- Number of layers of cartons in pile: 10 layers maximum.
- Environmental conditions:
 - Temperature: 0°C to 40°C.
 - Humidity: 60% RH or less (at 40°C). No dew condensation even at a low temperature and high humidity.
 - Atmosphere: Harmful gases such as acid and alkali which corrode electronic components and wires must not be detected.
 - Storage Period: Approximately three months.
 - Opening of Package: To prevent the TFT-LCD module from being damaged by static electricity, adjust the room humidity to 50% RH or higher and provide an appropriate measure for electrostatic grounding before opening the package.

Result Evaluation Criteria

Under the display quality test conditions with normal operation state, there shall be no change which may affect practical display function.

OTHER INFORMATION

If any problem should arise from this specification, the supplier and user should work out a mutually acceptable solution.

COCOM

This product falls under 'strategic product' according to the export trade control ordinance in force. Export of the item requires an export license issued by the related authorities.

Please confirm with Sharp whether the license is necessary since the ordinance may be revised by the authorities.

RELIABILITY TEST ITEMS

NUMBER	TEST ITEM	CONDITIONS
1	High Temperature Storage Test	$t_A = 60^\circ\text{C}$, 240 H
2	Low Temperature Storage Test	$t_A = -25^\circ\text{C}$, 240 H
3	High Temperature and High Humidity Operation Test	$t_A = 40^\circ\text{C}$, 95% RH, 240 H
4	High Temperature Operation Test	$t_A = 40^\circ\text{C}$, 240 H
5	Low Temperature Operation Test	$t_A = 0^\circ\text{C}$, 240 H
6	Electrostatic Discharge Test	± 200 V, 200 pF (0 Ω), Once for each terminal
7	Shock Test	100 G, 6 ms, $\pm X/\pm Y/\pm Z$, three times for each direction (JIS C7021, A-7 Condition C)
8	Vibration Test	Frequency range: 10 to 55Hz Stroke: 1.5 mm Sweep: 10 Hz to 55 Hz to 10 Hz Two hours for each direction of X/Y/Z (six hours total) (JIS C7021, A-10 Condition A)
9	Heat Shock Test	-25°C to $+60^\circ\text{C}$ /5 cycles, (two hours/cycle) (1H) (1H)

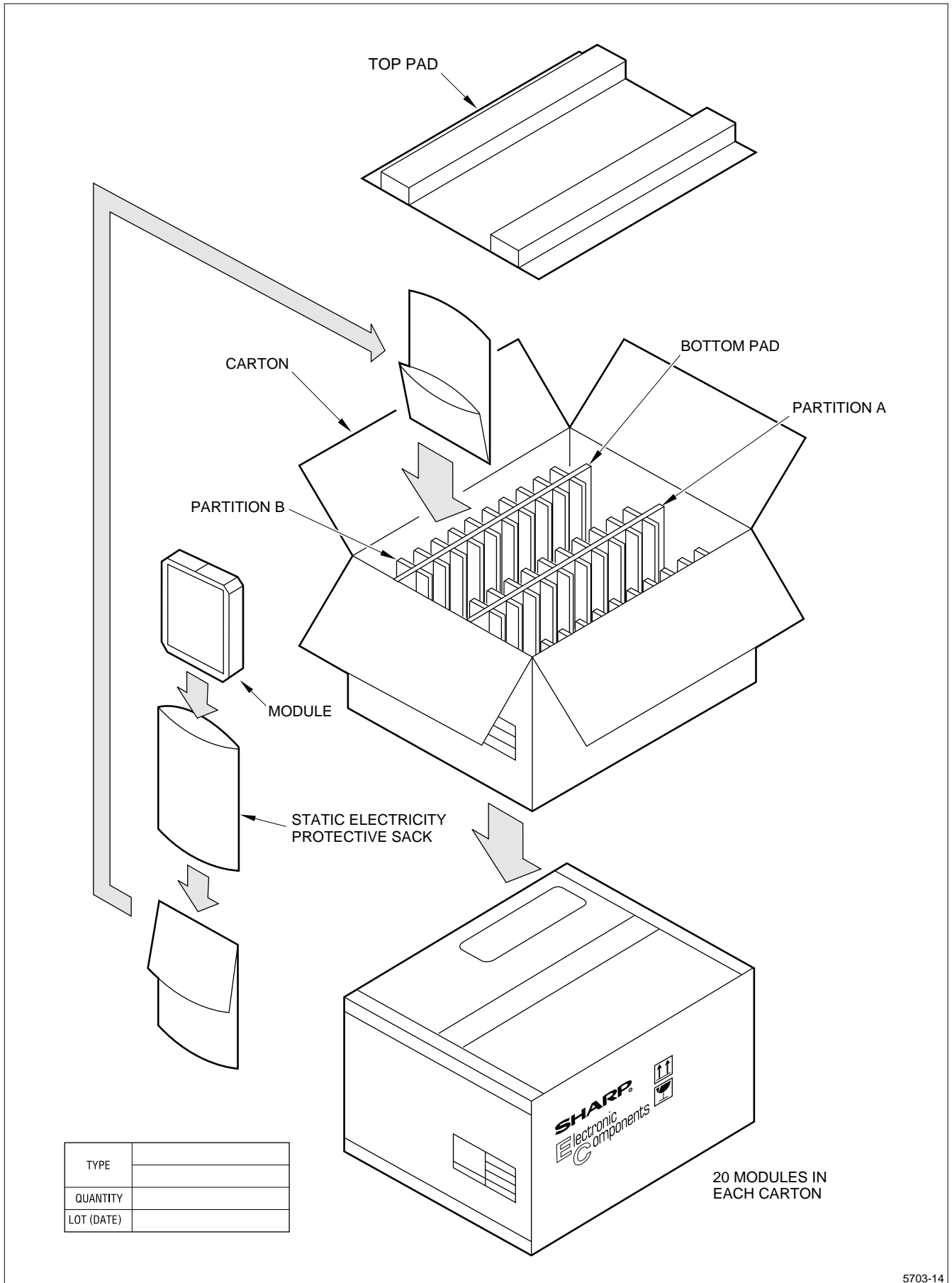

5703-14

Figure 13. Packing Form

CONSTRUCTION OF TFT-LCD MODULE

TFT-LCD module is composed of an LCD panel, driver ICs for the LCD panel, a control circuit for the driver ICs, a video signal processing circuit (video interface circuit) peculiar to LCD, and a backlight.

The driver ICs are divided into two types: a source driver (data driver) which receives RGB signals and sends them sequentially by one horizontal line of the LCD panel, and a gate driver (scan driver) which scans 240 gate lines of the LCD panel.

The circuit diagram is shown in Figure 3.

The module displays an image on the LCD panel as it receives power supplies (V_{SH} , V_{SL}), composite video signal, RGB video signals, DC bias voltage of common electrode driving signal (V_{CDC}), selection signal of composite and RGB video signals (VSW), brightness adjusting DC voltage (BRT), color gain adjusting DC voltage (COL), tint adjusting DC voltage (TIN), and contrast adjusting DC voltage (CNT), from the exterior.

The composite video signal is subject to synchronous separation in the module and used to write a video signal accurately on each pixel on the module.

The control circuit receives composite synchronizing signal separated in the video interface circuit, generates clock pulses synchronized with the composite synchronizing signal and gate and source drivers-driving signals, and outputs internal horizontal synchronizing signal (\overline{HSY}), internal vertical synchronizing signal (\overline{VSX}) and polarity inversion signal (FRP).

The voltage level of RGB video signals applied to the liquid crystal layer of each pixel through the source driver and TFT is about $3.7 V_{P-P}$ from black to white level. In order to prevent the electro-chemical decomposition of the liquid crystal, it is necessary to apply AC voltage to the liquid crystal. For this purpose, the polarity of the video signals must be alternated. Since the amplification and polarity inversion of the video signals are performed in the video interface circuit in the module using the polarity inversion signal (FRP), composite video signal of $1.0 V_{P-P}$ or standard analog RGB signals of $0.7 V_{P-P}$, may be used for both of the inputs to the module.

Power supplies to this module are 5 V (V_{SH}), 0 V (GND), and -8 V (V_{SL}). Control IC operates on 0 V to 5 V line so that it outputs \overline{HSY} and \overline{VSX} at 0 V to 5 V level. Power supplies to the video interface circuit are V_{SH} and V_{SL} .

VSW is used to select composite or RGB video signals. VSW selects composite video signal when it is 'High' or open, and selects RGB signals when it is 'Low.'

BRT, COL, TIN, CNT and V_{CDC} are adjusted to the optimum value on shipping.

The module contains backlight (cold cathode fluorescent tubes) but not a driving circuit for the backlight. Therefore, it is necessary to install a DC/AC inverter for driving the fluorescent tubes.

Standard DC/AC inverter (Model name: LQ0J04 is available as an option.

In addition, the backlight of the module is designed to be replaceable, and backlight unit (Model name: LQ0B04) is available as a service part for the replacement.

EXAMPLE OF TFT-LCD TV

Figure 14 shows a block diagram example of the TFT-LCD module applied to a TV set.

The block enclosed by the dotted line is the TFT-LCD module.

Other signal processing systems are the same as those in ordinary CRT-TV's.

The following seven signals must be supplied to this module from the exterior:

- Composite video signal: VBS
- Standard analog RGB video signals
- Signal for selecting input video signals: VSW
- DC bias voltage of common electrode driving signal: V_{CDC}
- Brightness adjusting DC voltage: BRT
- Color gain adjusting DC voltage: COL
- Tint adjusting DC voltage: TIN

The following two signals are output from this module to the exterior:

- Internal horizontal synchronizing signal: \overline{HSY}
- Internal vertical synchronizing signal: \overline{VSX}

When this module is applied to a TV set, for example, \overline{HSY} and \overline{VSX} are used to display selected channel number and characters on the screen.

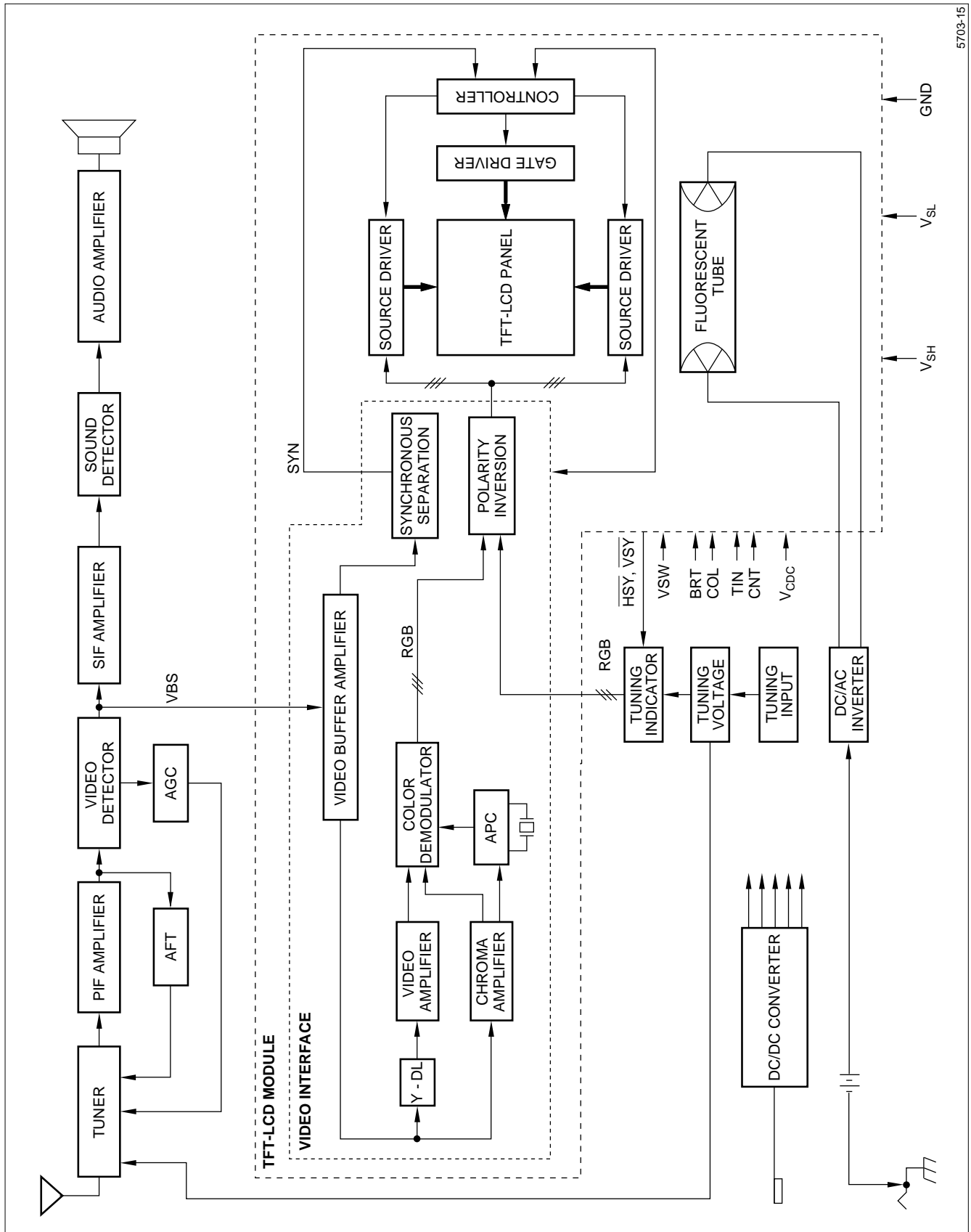

5703-15

Figure 14. Block Diagram of TFT-LCD TV Set

ADJUSTING METHOD OF OPTIMUM COMMON ELECTRODE DC BIAS VOLTAGE

To obtain optimum DC bias voltage of common electrode driving signal (V_{CDC}), photoelectric devices are very effective, and the accuracy is within 0.1 V. (In visual examination method, the accuracy is about 0.5 V because of the difference among individuals.)

To gain optimum common electrode DC bias voltage, there are two methods which use photoelectric devices. The value of optimum DC bias voltage is the same in both methods:

- **Measurement of Flicker:**
DC bias voltage is adjusted so as to minimize 60 Hz (30 Hz) flicker.
- **Measurement of Contrast:**
DC bias voltage is adjusted so as to minimize the photoelectric output voltage.

Measurement of Flicker

Photoelectric output voltage is measured by an oscilloscope at a system shown in Figure 15.

DC bias voltage must be adjusted to minimize the 60 Hz (30 Hz) flicker with DC bias voltage changing slowly (Figure 16).

Measurement of Contrast

Photo-electric output voltage is measured by oscilloscope or X-Y recorder by using the system in Figure 15. Common electrode DC bias voltage must be adjusted so as to minimize the photoelectric output voltage with DC bias voltage changing slowly (Figure 17).

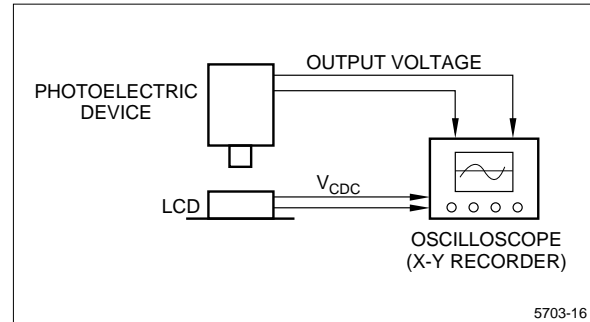

Figure 15. Measurement System

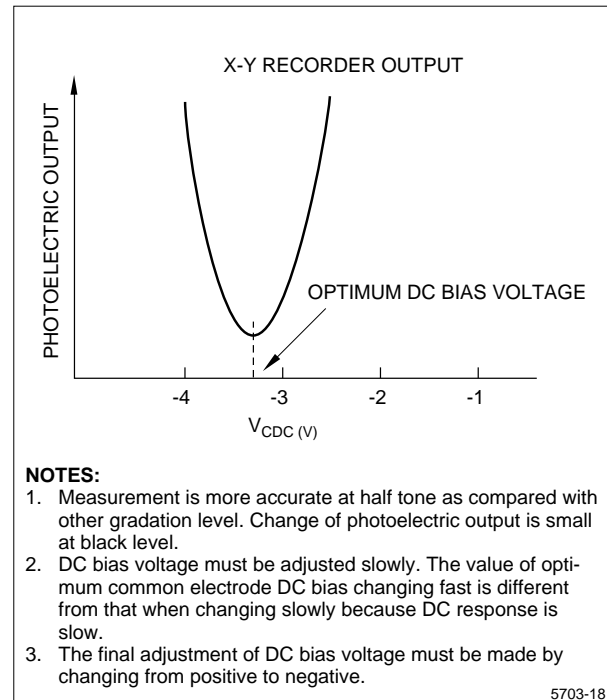

Figure 17. Optimum Common Electrode DC Bias Voltage By Measurement of Contrast

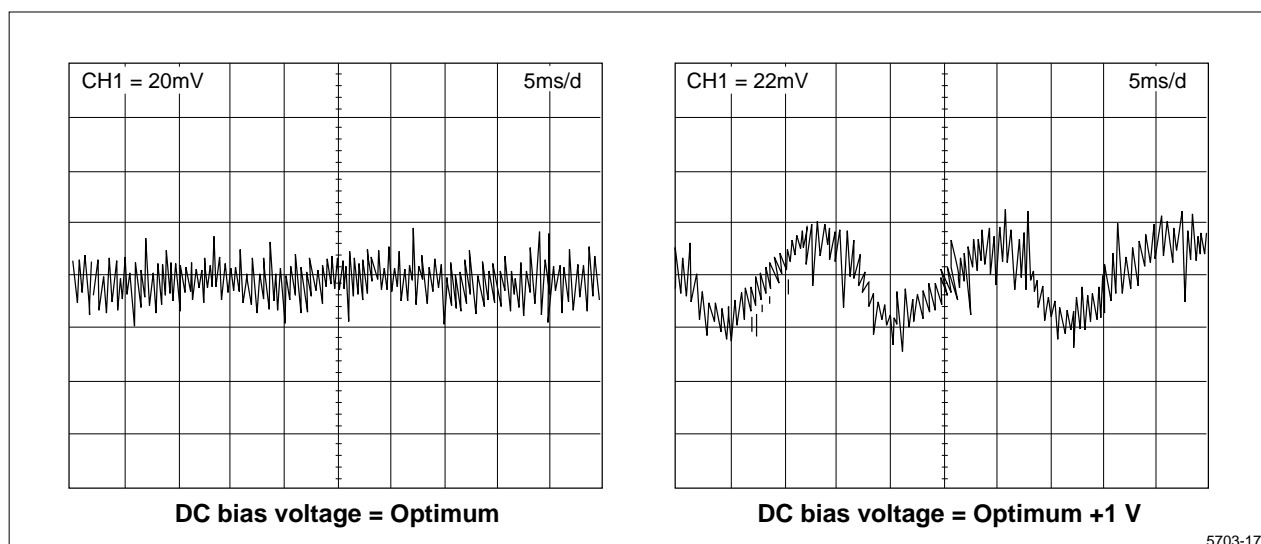

Figure 16. Waveform of Flicker

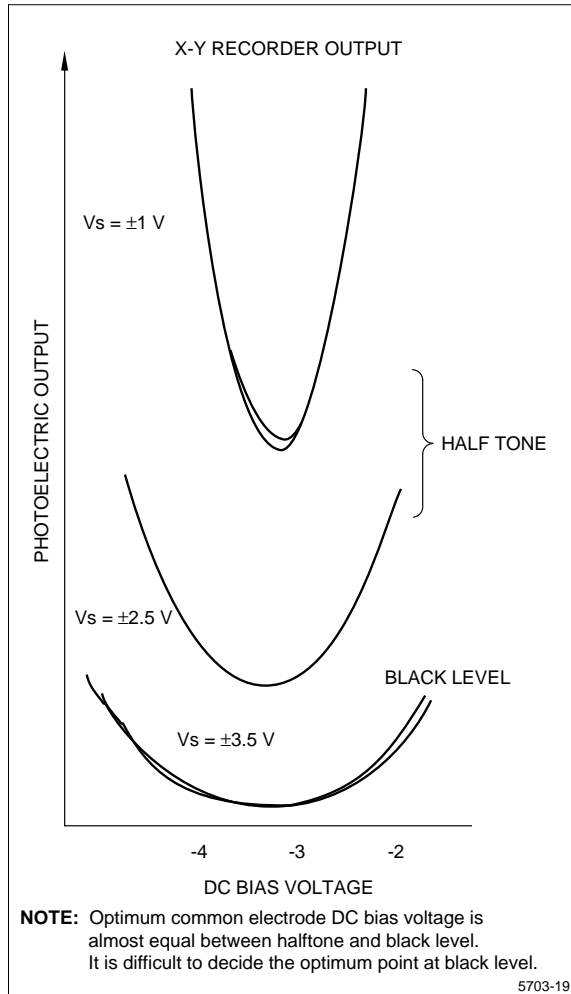

Figure 18. Relation Between Gradation Level and DC Bias Voltage

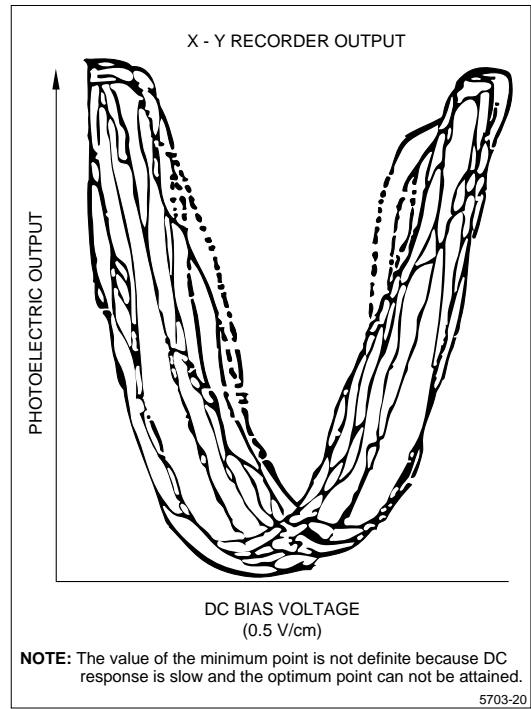

Figure 19. Output Voltage With DC Bias Voltage Changing Fast

OUTLINE DIMENSIONS

